

MADISON AVE.

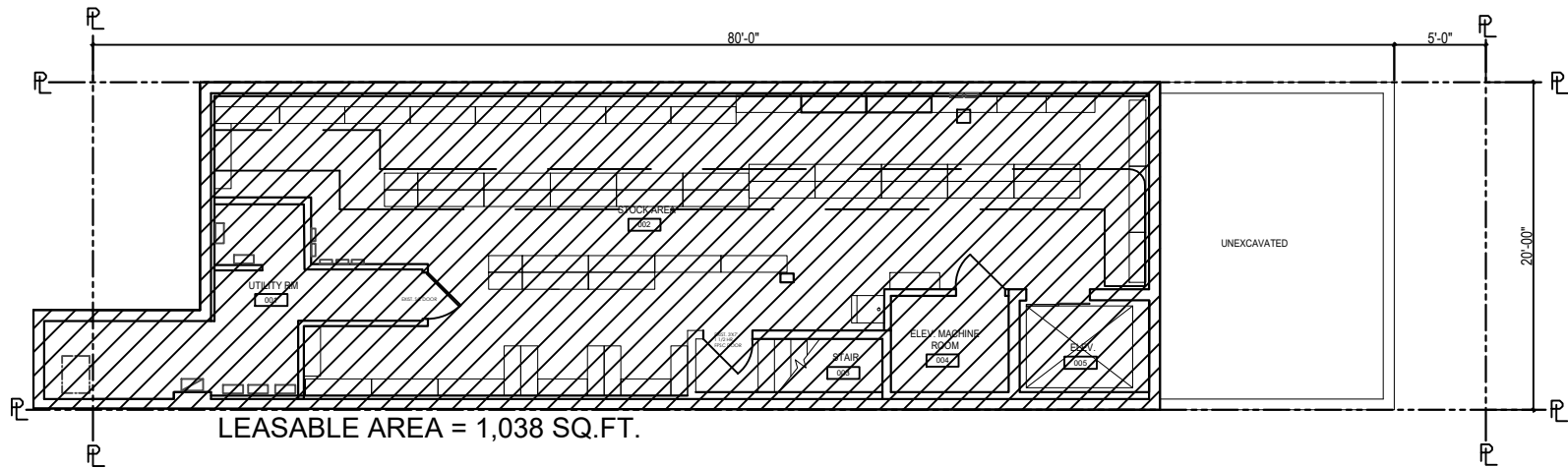

**BODNAR ARCHITECTURE P.C.**  
675 Madison Avenue Suite 3R, New York NY 10021  
P. 212 921 4466 - F. 212 730 1246

RENTAL PLAN FOR:  
**519 MADISON AVE**  
NEW YORK, NY

THESE DRAWINGS ARE:  
**CELLAR LEASING**



DWG. NAME:  
**519 MADISON LEASING**

DATE:  
11-20-20

SCALE:  
3/8"=1'-0"

THIS DIAGRAM IS SOLELY FOR THE PURPOSES OF IDENTIFYING THE PREMISES. ALL DIMENSIONS ARE APPROXIMATE. THE LANDLORD MAKES NO REPRESENTATION AS TO THE DIMENSIONS AND THE SQUARE FOOTAGE OF THE PREMISES.

MADISON AVE.

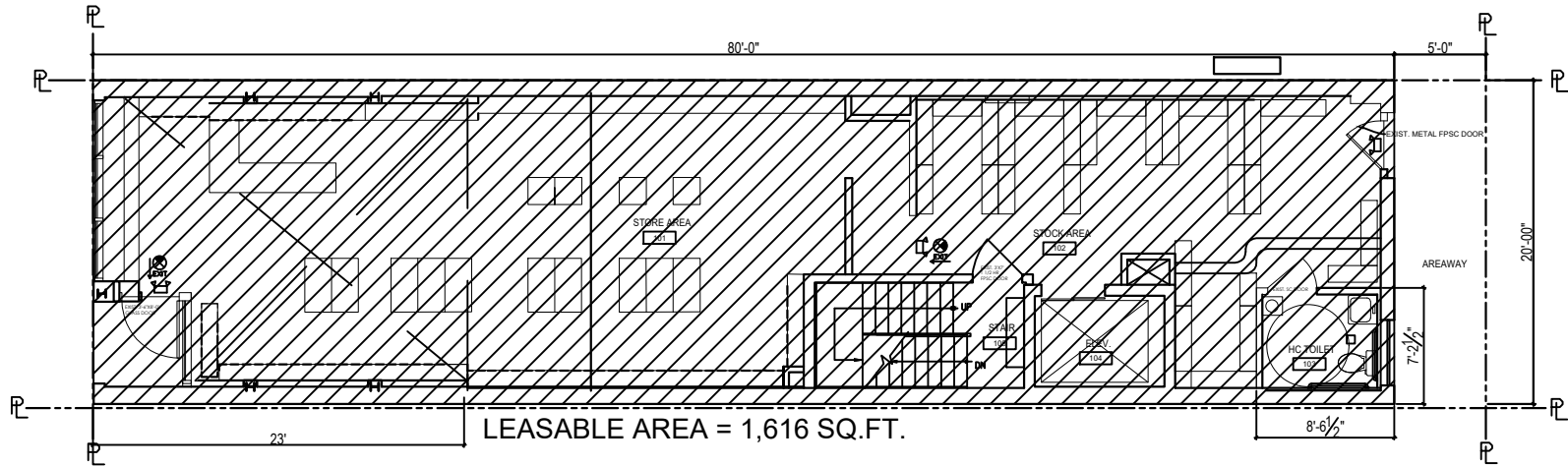

LEASEABLE AREA = 1,616 SQ.FT.

**BODNAR ARCHITECTURE P.C.**  
675 Madison Avenue Suite 3R, New York NY 10021  
P. 212 921 4466 - F. 212 730 1246

RENTAL PLAN FOR:  
**519 MADISON AVE**  
NEW YORK, NY

THESE DRAWINGS ARE:  
**FIRST FLOOR LEASING**



DWG. NAME:  
**519 MADISON LEASING**

DATE:  
11-20-20

SCALE:  
3/8" = 1'-0"

THIS DIAGRAM IS SOLELY FOR THE PURPOSES OF IDENTIFYING THE PREMISES. ALL DIMENSIONS ARE APPROXIMATE. THE LANDLORD MAKES NO REPRESENTATION AS TO THE DIMENSIONS AND THE SQUARE FOOTAGE OF THE PREMISES.

MADISON AVE.

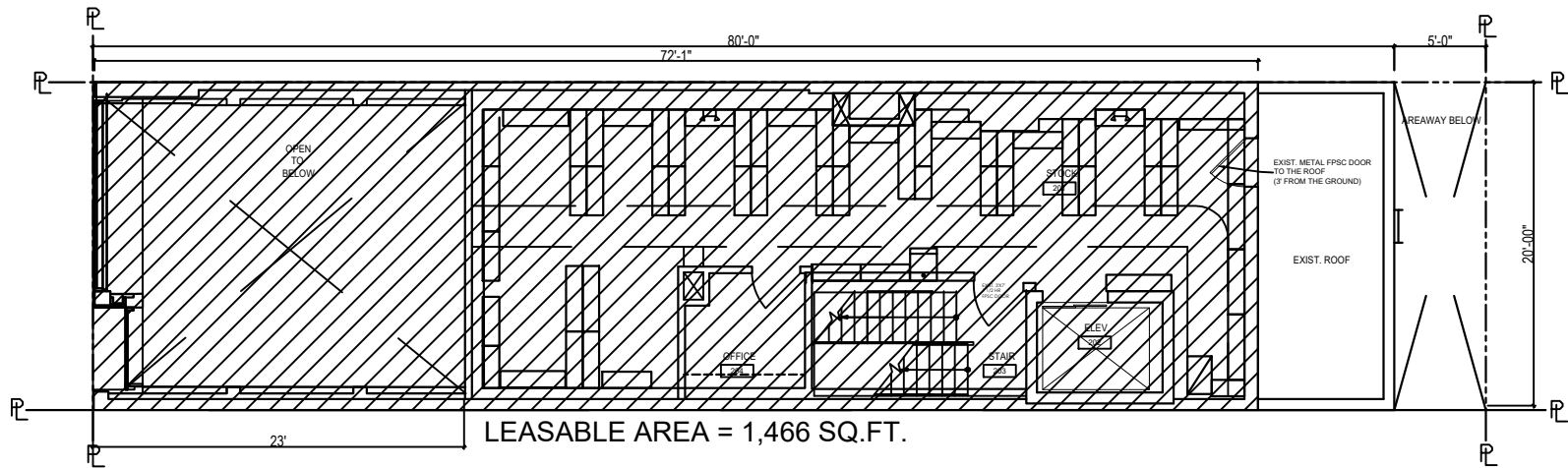

**BODNAR ARCHITECTURE P.C.**  
675 Madison Avenue Suite 3R, New York NY 10021  
P. 212 921 4466 - F. 212 730 1246

RENTAL PLAN FOR:  
**519 MADISON AVE**  
NEW YORK, NY

THESE DRAWINGS ARE:  
**SECOND FLOOR LEASING**



DWG. NAME:  
**519 MADISON LEASING**

DATE:  
11-20-20

SCALE:  
3/8" = 1'-0"

THIS DIAGRAM IS SOLELY FOR THE PURPOSES OF IDENTIFYING THE PREMISES. ALL DIMENSIONS ARE APPROXIMATE. THE LANDLORD MAKES NO REPRESENTATION AS TO THE DIMENSIONS AND THE SQUARE FOOTAGE OF THE PREMISES.

MADISON AVE.

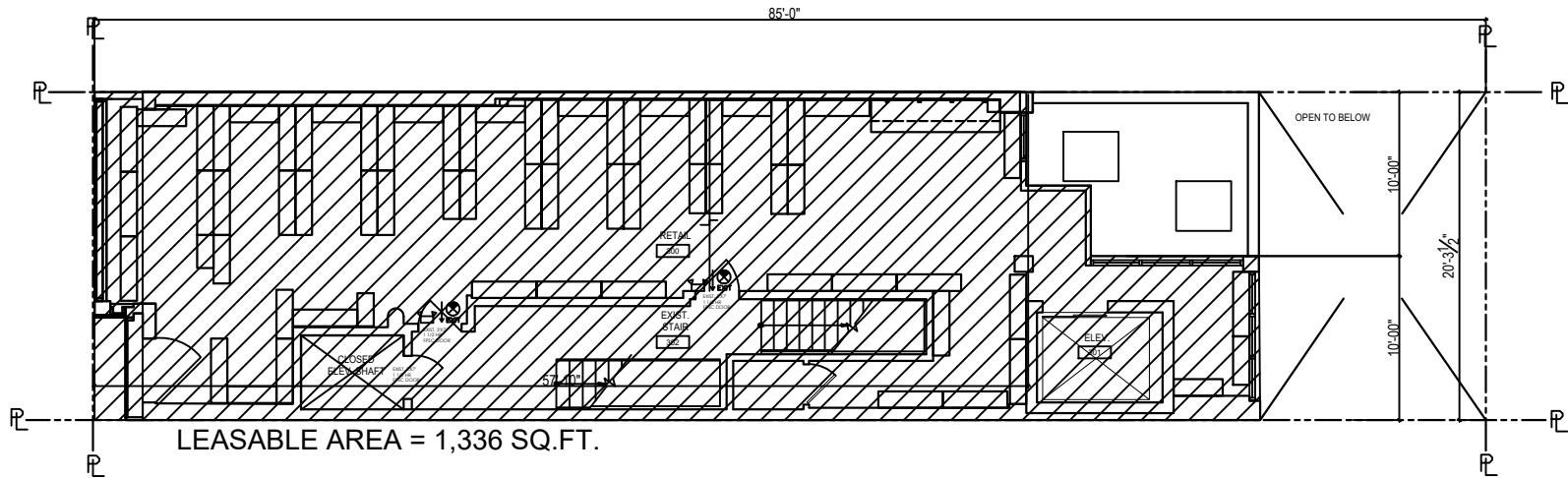

LEASABLE AREA = 1,336 SQ.FT.

**BODNAR ARCHITECTURE P.C.**  
675 Madison Avenue Suite 3R, New York NY 10021  
P. 212 921 4466 - F. 212 730 1246

RENTAL PLAN FOR:  
**519 MADISON AVE**  
NEW YORK, NY

THESE DRAWINGS ARE:  
**THIRD FLOOR LEASING**



DWG. NAME:  
**519 MADISON LEASING**

DATE:  
**11-20-20**

SCALE:  
**3/8"=1'-0"**

THIS DIAGRAM IS SOLELY FOR THE PURPOSES OF IDENTIFYING THE PREMISES. ALL DIMENSIONS ARE APPROXIMATE. THE LANDLORD MAKES NO REPRESENTATION AS TO THE DIMENSIONS AND THE SQUARE FOOTAGE OF THE PREMISES.

MADISON AVE.

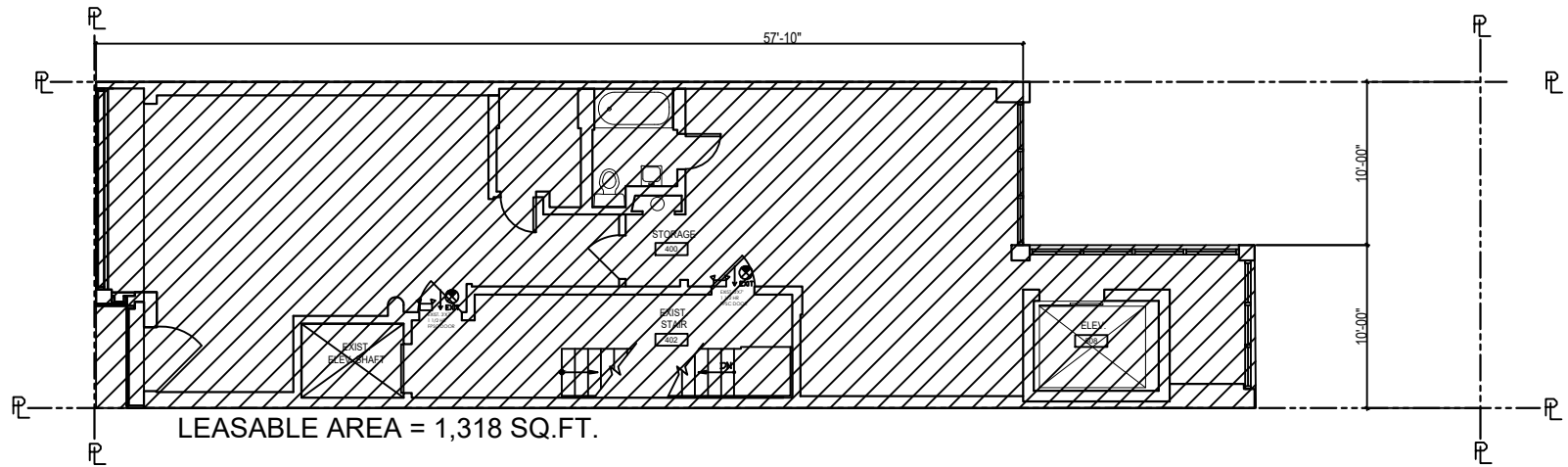

**BODNAR ARCHITECTURE P.C.**  
675 Madison Avenue Suite 3R, New York NY 10021  
P. 212 921 4466 - F. 212 730 1246

RENTAL PLAN FOR:  
**519 MADISON AVE**  
NEW YORK, NY

THESE DRAWINGS ARE:  
**FOURTH FLOOR LEASING**



DWG. NAME:  
**519 MADISON LEASING**

DATE:  
**11-20-20**

SCALE:  
**3/8"=1'-0"**

THIS DIAGRAM IS SOLELY FOR THE PURPOSES OF IDENTIFYING THE PREMISES. ALL DIMENSIONS ARE APPROXIMATE. THE LANDLORD MAKES NO REPRESENTATION AS TO THE DIMENSIONS AND THE SQUARE FOOTAGE OF THE PREMISES.

MADISON AVE.

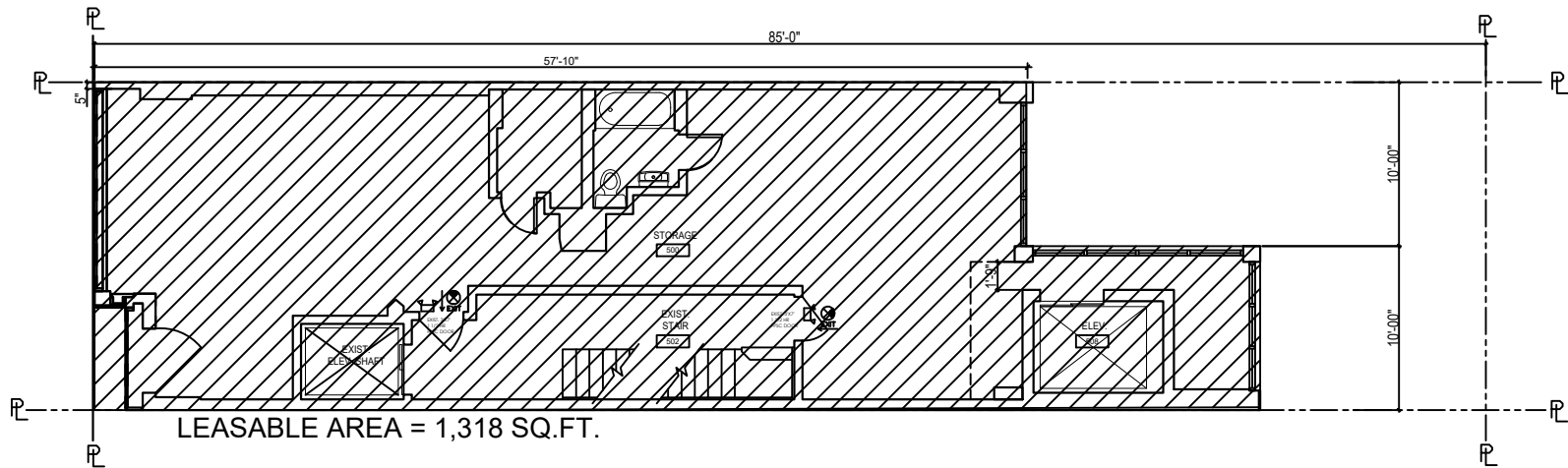

LEASABLE AREA = 1,318 SQ.FT.

**BODNAR ARCHITECTURE P.C.**  
675 Madison Avenue Suite 3R, New York NY 10021  
P. 212 921 4466 - F. 212 730 1246

RENTAL PLAN FOR:  
**519 MADISON AVE**  
NEW YORK, NY

THESE DRAWINGS ARE:  
**FIFTH FLOOR LEASING**



DWG. NAME:  
**519 MADISON LEASING**

DATE:  
11-20-20

SCALE:  
3/8" = 1'-0"

THIS DIAGRAM IS SOLELY FOR THE PURPOSES OF IDENTIFYING THE PREMISES. ALL DIMENSIONS ARE APPROXIMATE. THE LANDLORD MAKES NO REPRESENTATION AS TO THE DIMENSIONS AND THE SQUARE FOOTAGE OF THE PREMISES.